

12V / 100A DC Unidirectional Solid-State Relay

– TL-SSR12100DCU –

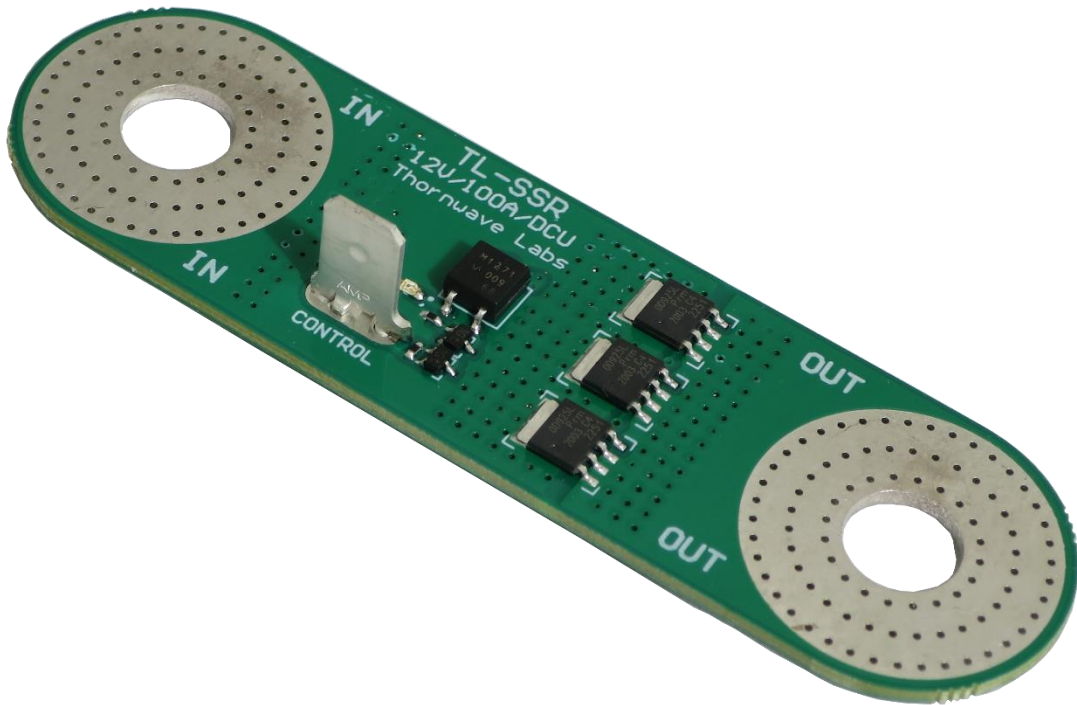

BRIEF

Congratulations for purchasing an SSR from the TL-SSR family of solid-state relays. The Thornwave Labs SSRs are built with performance in mind. We pay attention to turn-on time, turn-off time and most importantly current carrying capability. Unlike other SSR manufacturers, our relays are rated for continuous operation under the specified conditions. The voltage drop while in the ON state is very low. The TL-SSR line of relays have only three terminals, INPUT, OUTPUT and CONTROL. To turn on, connect the CONTROL terminal to ground. To turn off leave the CONTROL terminal floating (unconnected). SSRs come in two flavors: unidirectional and bidirectional. The unidirectional ones cut off the current flow in one direction, from input to output. Current from output to input (reverse current) will continue to flow even when the SSR is in the OFF state. This is the standard behavior of mostly all MOSFET based SSRs. Care should be taken to not allow current to flow backwards when the SSR is in the OFF state. This would cause a voltage drop of 0.7V across it and the SSR would quickly exceed its maximum power dissipation and get damaged. Essentially, the unidirectional SSR can be viewed as a diode with the anode as output and cathode as input. The actual switch is in parallel with the diode (see **Figure 1**). Bidirectional SSRs are true switches that interrupt current flow in both directions but at the expense of a higher voltage drop, dissipated power, and cost. A bidirectional SSR can be made using two unidirectional SSRs. Connect the INPUT terminals together. Connect the CONTROL terminals together. Use the two remaining OUTPUT terminals as the IN/OUT of the new bidirectional SSR and the CONTROL terminals for control (see **Figure 3**). This arrangement will drop twice the voltage of one SSR alone. For more current carrying capability, multiple SSRs can be wired in parallel paying attention to connect the SSRs with wires of equal length to distribute the current evenly between them. For best results use bus bars.

FEATURES

- MOSFET based, DC, unidirectional
- Withstands up to 20V (works in all 12V systems)
- Rated for continuous operation at up to 100A
- Withstands 150A for 1 minute
- Low control terminal current (less than 13mA)
- Low voltage drop even at maximum rated current (less than 30mV)
- LED indicator indicates when the SSR is ON
- ANL fuse form factor, fits inside an ANL fuse holder or can be used on bus bars
- Quick turn-on and turn-off time
- Can be wired in parallel for increased current handling capability

TERMINAL DESCRIPTION / INTERNAL DIAGRAM

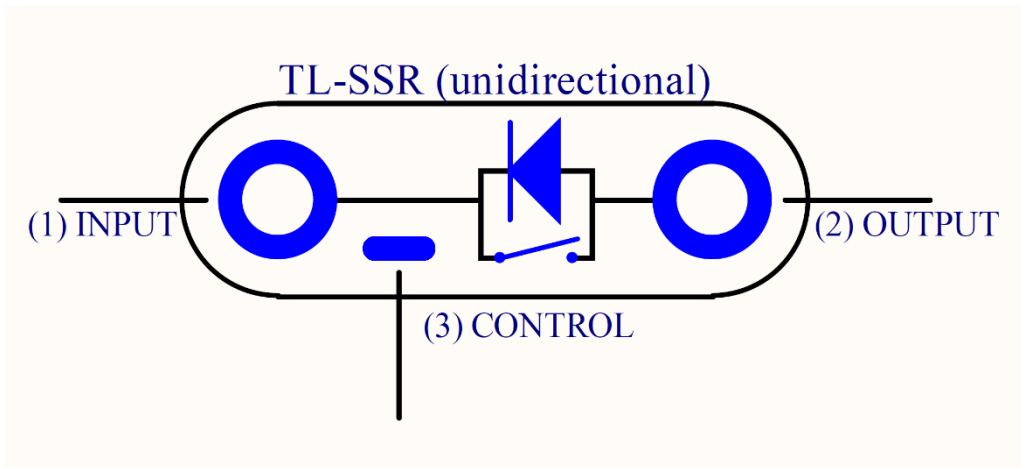

Figure 1: Terminal description / internal diagram

No.	Name	Terminal Description
1	INPUT	Relay input (current flows from INPUT to OUTPUT)
2	OUTPUT	Relay output (current flows from INPUT to OUTPUT)
3	CONTROL	Control terminal. Connect to ground to turn ON. Leave floating to turn OFF.

Do not overtighten the cable lugs on the INPUT and OUTPUT terminals!

The CONTROL terminal requires a ¼" female blade terminal. A right-angle terminal is required if the SSR is mounted inside an ANL fuse holder.

SPECIFICATIONS

Absolute Maximum Ratings ⁽¹⁾⁽²⁾	
Minimum voltage at INPUT terminal	6V
Maximum voltage at INPUT/OUTPUT terminals	20V
Maximum voltage between INPUT and CONTROL	+20V
Maximum current (INPUT to OUTPUT) – continuous ⁽³⁾	100A
Maximum current (INPUT to OUTPUT) – max 1 minute	150A
Maximum current (OUTPUT to INPUT) – in ON state	100A
Maximum current (OUTPUT to INPUT) – in OFF state	4A ⁽⁴⁾
Operating Temperature	-30°C to +85°C

1. Stresses greater than those listed under “Absolute Maximum Ratings” may cause permanent damage to the device.
2. All voltages are referenced to GROUND, unless otherwise specified
3. SSR temperature has to be below 85°C
4. This condition will cause excessive heating and damage to the SSR. Do not allow current to flow from OUTPUT to INPUT when the SSR is OFF. A charger, for example, can be connected before the SSR, straight to the battery. Alternatively, a bidirectional SSR can be used.

Performance Parameter	Value
Voltage drop across INPUT-OUTPUT	max 30mV (for I ≤ 100A)
Typical resistance (in the ON state)	0.25mOhm
CONTROL current (when connected to GROUND)	max 13mA
Turn ON time (when all voltages within specifications)	3ms
Turn OFF time	1us
Turn ON delay (CONTROL to actual turn ON)	2.5ms
Turn OFF delay (CONTROL to actual turn OFF)	800us

DIMENSIONS

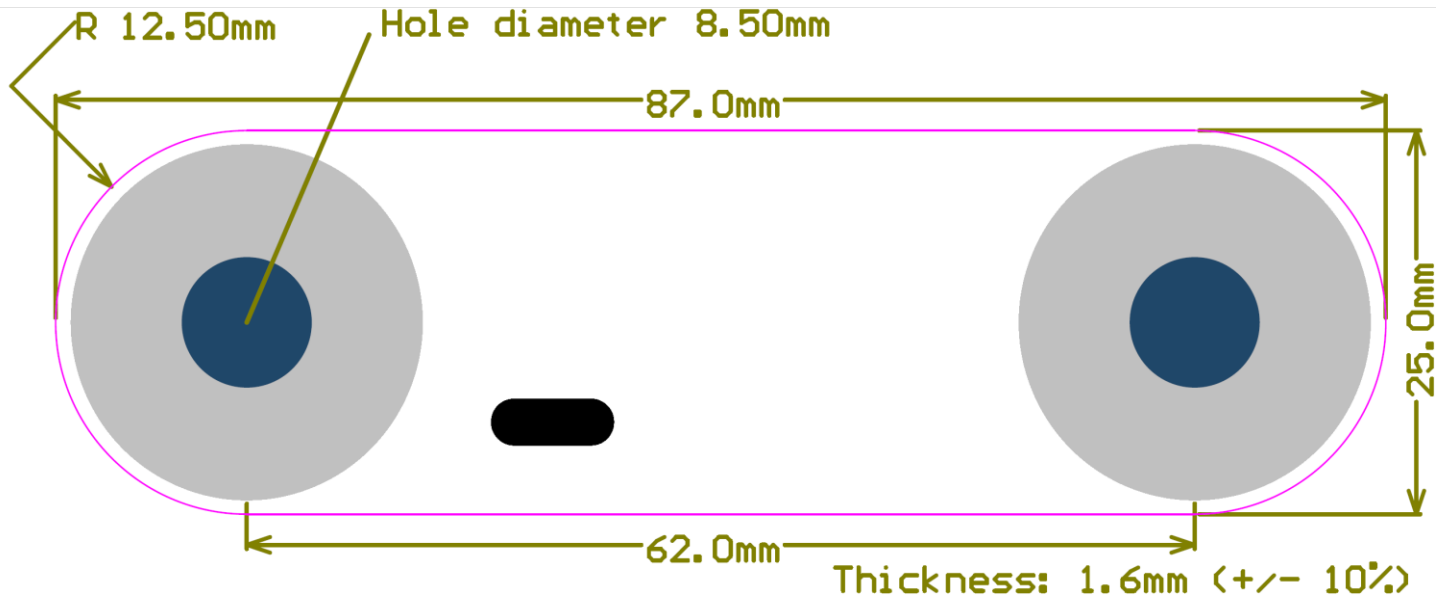

Figure 2: Mechanical dimensions

WIRING DIAGRAMS

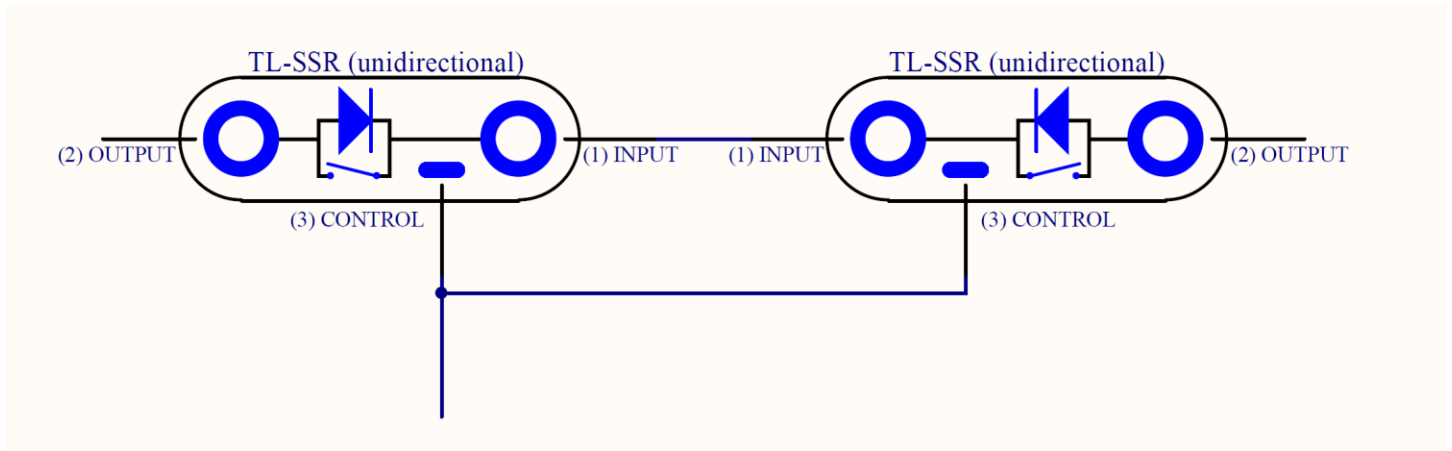

Figure 3: Bidirectional SSR built with two TL-SSR devices.

ORDERING

Part Number	Description
TL-SSR12100DCU	12V / 100A DC Unidirectional Solid State Relay

Changelog:

Date	Revision Description
9/2/2018	Initial version
9/17/2018	Added SSR enclosure image
10/31/2018	Added specifications
7/1/2020	Updated specifications to reflect new SSR architecture.