

PowerMon

Bluetooth Low Energy

Advanced Battery Monitor / DC Power Meter

– QUICK START GUIDE –

This document is meant to be a quick start guide for installing and configuring the PowerMon, Bluetooth Battery Monitor / DC Power Meter and does not contain in-depth details. For a complete manual please visit the product webpage at <https://www.thornwave.com/products/bluetooth-battery-monitor-dc-power-meter>

Package contents. The product has been shipped in a box containing the PowerMon device, an 8-pin female terminal block and a short piece of copper wire. From the factory, the device is configured to use the internal current shunt. All extra features are in the disabled state. No calibration has been applied to the current reading. If better accuracy is required, please read the “*Calibration*” section.

Required tools / materials. To complete the installation of the PowerMon device the following tools and materials are required:

- wire cutters / wire strippers
- small flat screwdriver
- long nose pliers
- external current shunt (if applicable)
- up to 6AWG wire for the high current connections (the aluminum set screw terminal blocks on the device). If using an external shunt larger wire may be required.
- 16-22 AWG wire for wiring the other signals. Different colors are recommended (red / black / green / yellow / blue)
- Terminals for connecting wires to the battery (usually 5/16” or 3/8” ring terminals)
- Crimping tool
- 2 screws (for mounting the device on a flat surface). These can be wood screws, plastic screws, or machine screws, depending on the surface the device will be mounted on. The device can also be mounted using double sticky tape or even plastic zip-ties.

SAFETY INSTRUCTIONS

Warning !

Read all the instructions and cautions before using the PowerMon device. Thornwave Labs Inc does not assume responsibility for any injury or property damage caused by improper installation, bad wiring or the use of PowerMon outside of its intended purpose. The device should be installed by a professional. Do not work on a live electrical system. Disconnect the power sources first (battery, shore power, solar panels, generator)!

Warning !

The PowerMon device should not be used for any medical purposes, life sustaining equipment, safety applications or any application where equipment failure can cause injury, death, fires, or any other hazard.

Warning !

There are no serviceable parts or fuses inside the power meter! Do not disassemble or attempt to repair! The unit operates with voltages up to 72V which can be lethal or cause serious and permanent injury.

Warning !

Do not submerge under water or other liquids. The device is weatherproof but not waterproof.

Warning !

The device is to be connected to DC circuits only, not exceeding 72V and 60A (using the integrated current shunt). Failure to do so will result in equipment damage. Higher currents are supported when using an external current shunt. Confirm that all connections are tight to avoid excessive heating and sparks. Never connect the V1 or V2 terminals to a power source without using a fuse or circuit breaker. A 0.1A to 2A fuse or circuit breaker is required.

Warning !

Batteries are dangerous! Do not short-circuit a battery or the battery monitor terminals. Batteries can produce flammable and explosive gases and can generate extremely high currents that can lead to serious consequences including explosion, fire, damage to equipment, personal injury and even death. It is the user's responsibility to operate the equipment in a safe manner. Do not charge batteries in an enclosed environment unless allowed by the manufacturer of the battery. Never connect a load to a battery without using fuses or circuit breakers properly sized for the wires / equipment.

Warning!

Although PowerMon-W coupled with a relay can disconnect power if an over-current condition occurs, it should not be used to replace circuit-breakers. A properly rated circuit breaker or fuse should be used to protect the load and the wiring!

TERMINAL DESCRIPTION / INTERNAL DIAGRAM

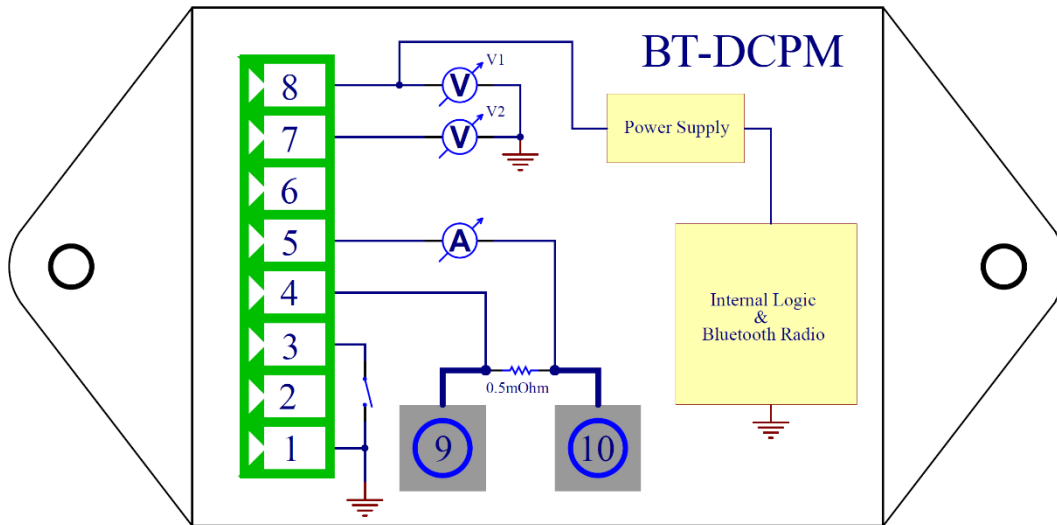

No.	Name	Terminal Description
1	GROUND	System ground
2	MF	Multi-function (for hardware revision 2.20 and up). Supports pushbutton input or external temperature sensor
3	RELAY	Relay output. It drives a mechanical or solid-state relay. To turn the relay on, the device is grounding this terminal internally.
4	ES1	External shunt connection. When using the internal current shunt connect this to ES2 (terminal 5)
5	ES2	External shunt connection. When using the internal current shunt connect this to ES1 (terminal 4)
6	NC	DO NOT CONNECT!
7	V2	Second monitored voltage. Can measure the voltage of a second battery.
8	V1	This is the main voltage that will be monitored. The device also draws its own power from this terminal.
9	IS1	Internal shunt connection. Do not connect if using an external shunt.
10	IS2	Internal shunt connection. Do not connect if using an external shunt.

Mounting the device

- Attach the device to a flat surface using two screws, double sticky tape or plastic zip-ties
- Mounting on a metallic surface or inside a metal enclosed space will substantially reduce the Bluetooth range. For best results mount in such a way so the radio signal will not be blocked. Keep in mind that at the Bluetooth frequency of 2.4GHz the radio signal travels only in a straight line and any obstacle in its path (walls, big objects) will interfere with it.
- If an external shunt is used, mount it as close as possible to the PowerMon device. The longer the wires that connect the external shunt to the device the more electrical noise they will pick up.

Wiring using the internal shunt (optional)

- If using the internal shunt, connect ES1 and ES2 (terminals 4 and 5) together using the piece of copper wire that was supplied with the device. Cut a shorter piece from the supplied wire and using a pair of long nose pliers, bend it in a U shape. Insert it into terminals 4 and 5 and tighten the terminals. There is no need to leave the wire too long – it should be flush with the terminal block.
- Connect up to 6 AWG wires to IS1 / IS2 (terminals 9 and 10). Please check the diagrams in the user manual. For now, it does not matter which wire goes where. If IS1 / IS2 are swapped the sign of the current reading changes. The target is to get the current to display positive when the battery is charging and negative when discharging. If the current sign is backwards, either swap the wires into IS1 / IS2 (terminals 9 and 10) or enable the “Flip Current Sign” option in the device configuration.

Wiring using an external shunt (optional)

- If using an external shunt connect ES1 / ES2 (terminals 4 and 5) to the measurement points on the shunt. Typically, these are smaller screws positioned inside of the larger high current connections of the shunt. Keep the wires as short as possible. Twisting them will reduce the noise even further. Avoid running these wires parallel to high current carrying wires. Doing so will introduce unwanted noise into the measurements. The target is to get the current to display positive when the battery is charging and negative when discharging. If the measured current has the wrong sign, there is no need to reverse the wires. The current sign can be flipped using the “Flip Current Sign” option in the device configuration.
- Connect the high current lugs of the external current shunt using wires of adequate size. Crimping of battery lugs may be required.
- **Do not connect terminals 9 and 10!**

Device power / voltage measurement

- Using a piece of 16-22AWG black wire, connect terminal 1 to the system ground (negative side of the battery / solar panels / power source / chassis)
- Using a piece of 16-22AWG red wire connect terminal 8 (V1) to the positive side of the power source using a fuse or circuit breaker in between 0.1A and 2A. This is here to protect the wiring so install it close to the battery.
- If applicable, connect terminal 7 (V2) to the second battery (or node in the system) that will be monitored. Use a similar fuse as well.

External relay (optional)

- If an external relay is used, connect one side of the coil to RELAY (terminal 3) and the other side to the load side of the shunt. In this case the battery voltage cannot exceed 32V (Check the user manual for more details). Use 16-22AWG wire. Crimping a female spade connector may be required. Choose blue or yellow, or any color different than black or red.
- If the Thornwave Labs SSR is used, connect RELAY (terminal 3) to the control terminal of the SSR

Check all the connections again. Verify that the high current wires are tight. Use fuses or circuit breakers where applicable. Once all these have been checked, insert the female terminal block into the PowerMon device and reconnect the battery or the power source. The device should become visible on any mobile device that supports Bluetooth Smart (LE) and is running the PowerMon app.

Mobile application

- Install the mobile application (PowerMonX) on your phone / tablet. This is available for free on Google Play Store and Apple App Store.
- The PowerMonX app should discover the PowerMon devices that are in range.
- Tap on a device to connect to it. If multiple devices show up and you are not sure which device is the one you wish to connect to, you can use the RSSI indicator and position the mobile device very close to the PowerMon you would like to identify. The RSSI will indicate a much stronger signal for that device. RSSI values are negative. -30dBm is a stronger signal than -60dBm.
- Once connected, tap on the top right corner on the 3 dots (application menu) and then tap on "Device Information". Tap on the rename button to rename the device. The default name is "PowerMon". Note that the name cannot be longer than 8 characters.
- This would also be a good time to update the firmware if any update is available. During the firmware update process, the power to the device should not be interrupted.
- Tap on the application menu again and then "Configuration". Configure the device appropriately (external shunt used). From the factory, the device is already configured to use the integrated shunt.

Offset zeroing

- Because of the extremely low voltage drop across the shunt resistor that the PowerMon-W must sense, offset is inevitable. If the current measurement displayed by the app is not zero even though the actual current is, this is called an offset. It can be zeroed.
- Make sure the current that passes through the external shunt is zero (no current). The best way to make sure this happens is to disconnect the wire from the load side of the shunt.
- Tap and hold on the current measurement and select "Zero Current Offset". This will bring the measurement value to zero (zero the offset).
- WARNING: If the actual current was not zero when the "Zero Current Offset" was performed, this value will become the new zero. This is wrong since you just introduced a very large current offset.

Calibration (optional)

- The only measurement that can be calibrated by the user is the current. If a better accuracy than an uncalibrated device offers (about 1%) is required, proceed with the device calibration. The offset should be zeroed before calibrating.
- Apply a known current (accurately measured using an external amp-meter)
- Tap and hold on the current measurement and select "Calibrate Current"
- Type the actual value of the current as indicated by the amp-meter and press OK. Note that if the calibration current and the uncalibrated current reading are different by more than 10%, the calibration is not performed.
- Changing the current shunt specifications under "Device Configuration" will remove both the calibration and the zeroing of the current reading.

TROUBLESHOOTING

Symptom: The device indicates some current but there is no current flowing through it (or the external shunt)

Possible Causes:

- If using the integrated shunt, terminals 4 and 5 may not be connected together. To fix this, connect terminals 4 and 5 together using the supplied copper wire.
- If the user performed the "Zero Current Offset" procedure, the device assumed that the external current was zero and applied an offset to the measurement in order to bring the indicated value to zero. If the actual device current was not zero at the time the "Zero Current Offset" was performed, the offset applied will not be correct which leads to the wrong reading. To fix this, make sure the actual current is zero (disconnect the load side of the shunt if required) and execute the "Zero Current Offset" procedure again.

Symptom: The PowerMonX app is not finding any device

Possible Causes:

- The PowerMon device is not powered. Check if power is available at the green connector terminals 8 and 1 (8 is positive, 1 is negative).
- The phone app does not have the permissions it requested when it was installed or on the first start
- The user tried to pair the PowerMon device as if it were a classic Bluetooth device. If this is the case, unpair the PowerMon, and use the app instead.

Symptom: The current reading is wrong

Possible Causes:

- The external shunt has not been configured properly. Go to "Device Configuration" -> "General Configuration" to fix that.
- The shunt is not connected properly to the PowerMon-W device. Check the shunt wires connect to terminals 4 and 5.